

A switcher for the 3.4GHz transverter



A Geelong Amateur Radio Club Project

The 3.4GHz transverter made from surplus 3.5GHz WiFi transceivers has proved very popular and we still get requests for a simplified switcher board.

This project uses mostly 0805 sized SMD components as well as some more conventional thru-hole components. It is designed around off the shelf components that can be purchased from a variety of component vendors.

Warning: This switcher is only useful with a barefoot panel as there is no timing control when switching from RX to TX and back. If you intend to add an external preamp or power amplifier or both you need to employ a proper sequencer like the MiniKits EME166.

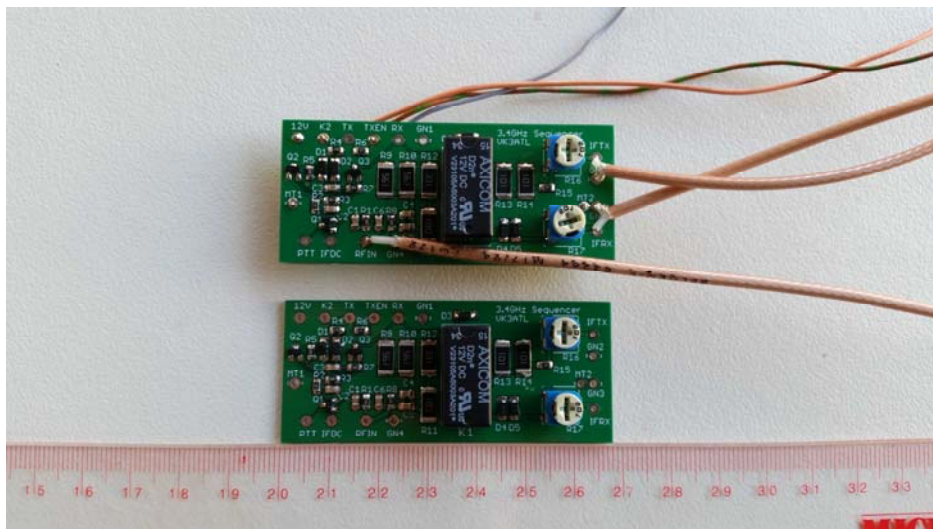

This document should be read in conjunction with the conversion notes for the 3.5GHz panel.

Construction

Leave the installation of the relay and trimpots until last making sure that you trim the relay pins as close to the board as possible. Be sure when mounting the switcher that these pins do not short to the groundplane of the main board.

Note the two ground pads on the switcher labeled MT1 and MT2. These can be used to attach the switcher to the main board. Insert two solder pins or heavy wires into these holes from the back of the switcher board.

Installation

Plan the location of the switcher then scrape away the solder mask on the main board in preparation for fitting. Check the location of the relay contacts against the main board and file away a small section to clear the relay pins. You may also want to scrape away some of the solder mask on the back of the switcher so you can solder the two board together. Check again for shorts then solder the switcher in to place.

Depending on your installation method a small amount of hot glue may be used to further secure the board if desired.

Testing

Test the board thoroughly before you install it.

- Apply 12V and ensure K1 pulls in immediately.
- Ground PTT and ensure K1 drops out.
- Apply 12V DC to IFDC via a 4k7 resistor and ensure K1 drops out.
- Confirm TX is < 3V during RX and 12V during TX
- Confirm TXEN is the same as TX.

Apply 2.5W to RFIN and ground PTT

- Confirm you can adjust R16 to get around 0dBm at IFTX

Note that input VSWR of the board is around 2.1:1. This should not have any impact on your IF radio.

If you prefer a lower VSWR increase the input attenuator from 3dB to 6dB or even 10dB. Take this extra attenuation into account when completing the modifications of your panel.

Component placement

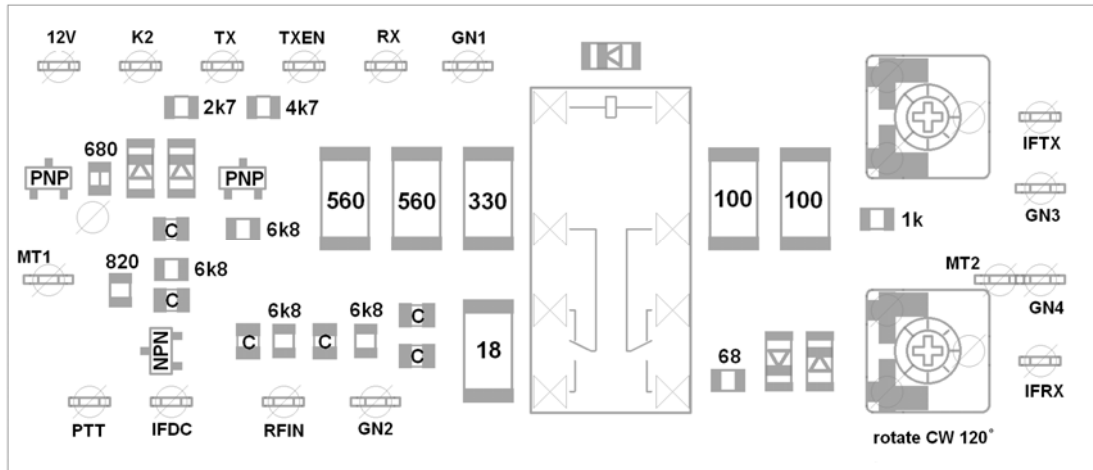

PTT, IFDC, TX & RX do not need wires connected to them. See the circuit diagram for further details.

- 12V goes to the main 12V supply
- K2 goes to the coil of the output coax relay
- IFTX goes to the input of the 24dB attenuator in the 480MHz TX filter
- IFRX goes to the output of the RX HPF
- GND1-4 Ground connections

Parts List

Make sure when substituting parts that the replacements are physically as well as electrically equivalent.

Part	Value	Package	Element 14 Order No
C1-C6	0.001	C0805	
D1-D5	1N4148W-7-F	SOD123	2306363
Q1	BC847CLT1G	SOT23	1459038
Q2,Q3	BC807-25	SOT23	1798084
R5	680	R0805	
R2	820	R0805	
R15	1k	R0805	
R4	2k7	R0805	
R6	4k7	R0805	
R1,R3,R7,R8	6k8	R0805	
R11	18 1W	R2512	1265175
R13,R14	100 1W	R2512	1265164
R12	330 1W	R2512	1265196
R9,R10	560 1W	R2512	1265216
R16,R17	200R	5mm spacing from MiniKits or Jaycar	
R18	68R	R0805	
K1	G5V-2/D2N-DC12	12V relay	1608360

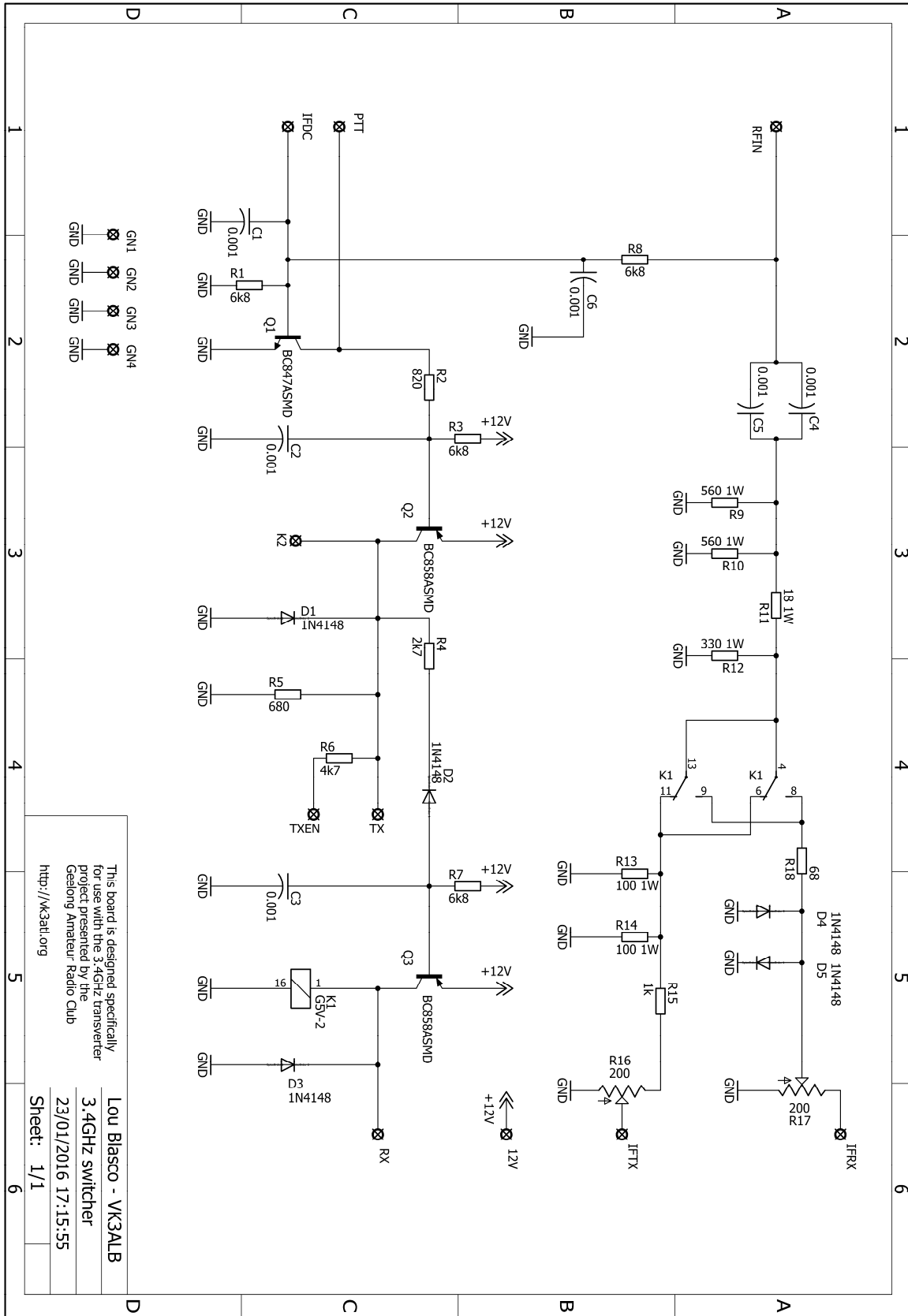

This board is designed specifically for use with the 3.4GHz transmitter project presented by the Geelong Amateur Radio Club
<http://vk3atl.org>

Lou Blasco - VK3ALB
 3.4GHz switcher
 23/01/2016 17:15:55
 Sheet: 1/1

Errata for PCB version 1.0

Depending on current draw from the external relay and perhaps an optional preamp, Q2 & Q3 should be replaced with a more substantial transistor like a [BC807](#). The BC557 transistors are rated to 100mA and are OK for a standard installation but extra current draw may push it over the edge.

Due to moderate power dissipation during TX it is necessary to increase the power handling of R5. Replace the single resistor with a pair of resistors in parallel.

Rotate RX trimpot R17 120° CCW so the wiper connects to the junction of D4 & D5.

Remove D4 and reinstall it to the right of D5. Cut the track between the pads for D4 & D5. Bridge a 68R resistor across the two separated pads.

